

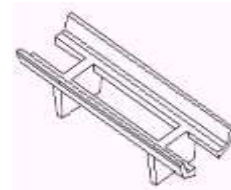

Planted Modular Walls



EVERGREEN®



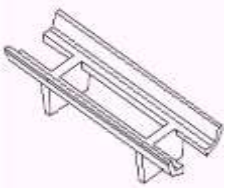

EVERGREEN® Walls

- ★ **precast gravity wall**
- ★ **made in monoblocks**
- ★ **self supporting**
- ★ **planted**



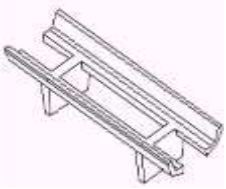

The Unit

2.3 ft. to 13.5 ft.
(1,33m to 4.21m)

16 ft. (5.0 or 5.40 m)

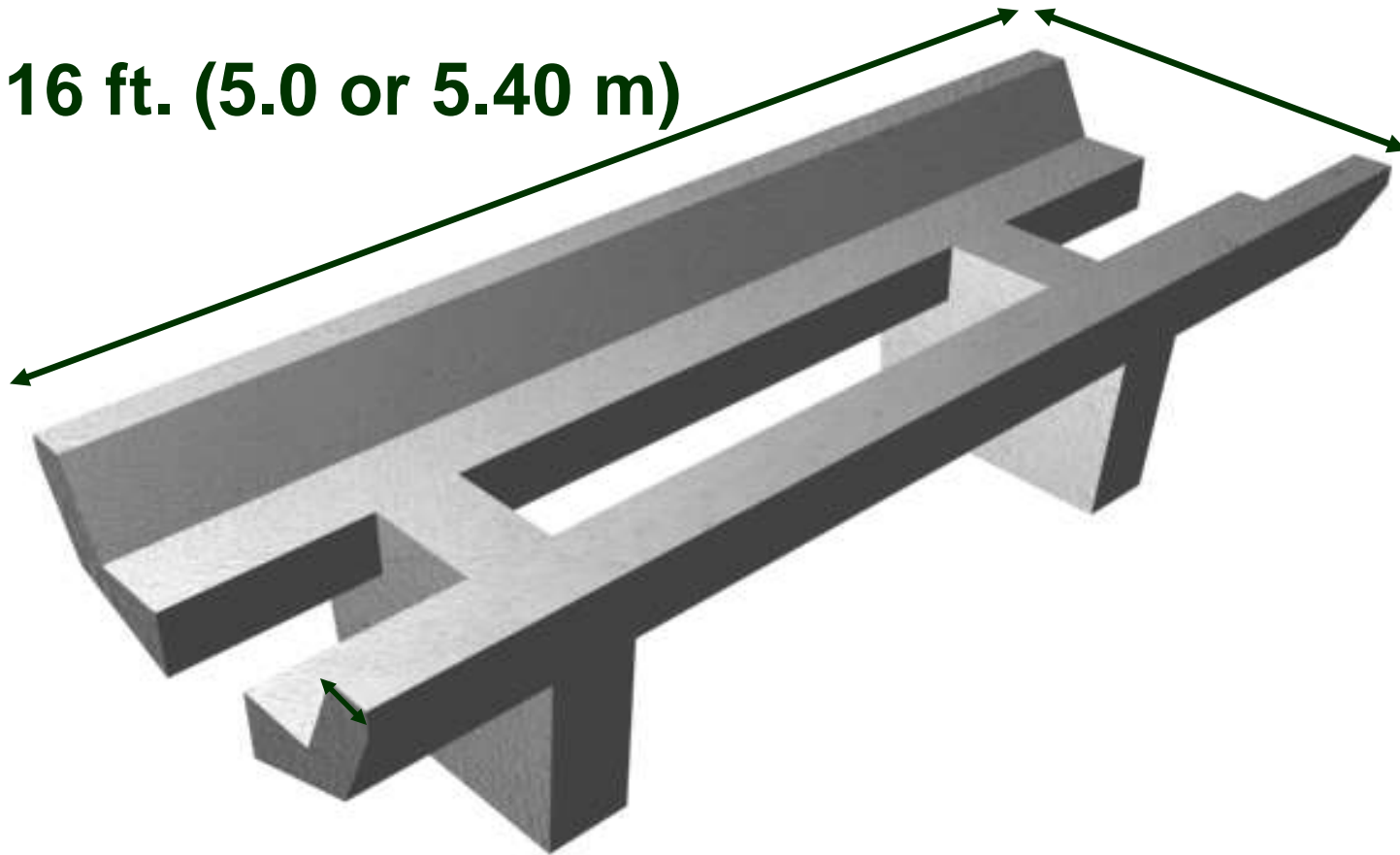

4.5" (0,11m)

* Height : 2.5 ft. (0,75 m)



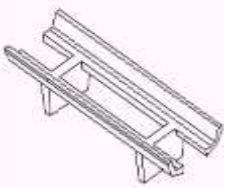

First Application

1. Retaining Walls



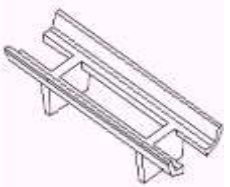

Retaining Wall Section

small berms

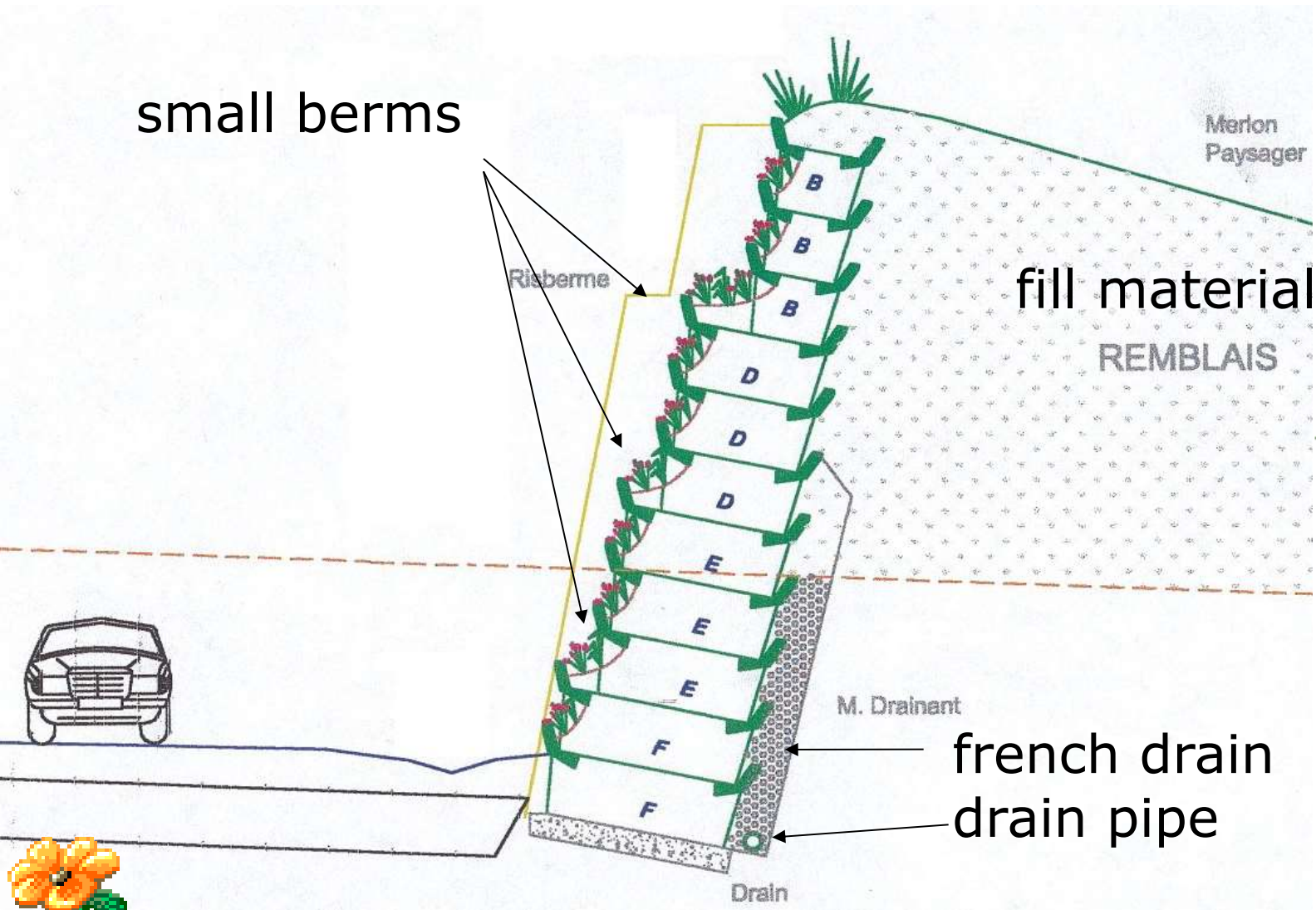

Risberme

Merlon
Paysager

fill material

REMBLAIS

M. Drainant

french drain
drain pipe

Drain



Erection of Retaining Wall

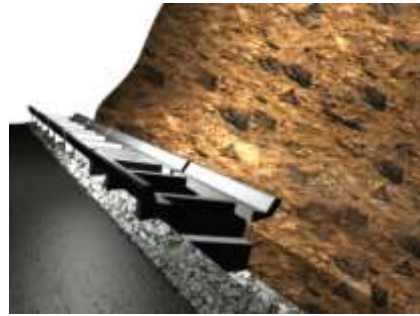
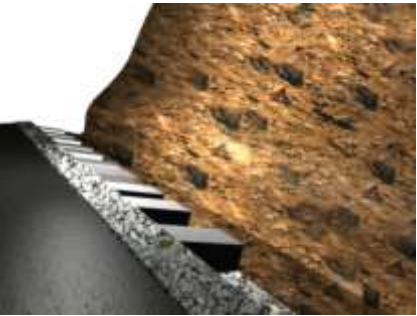

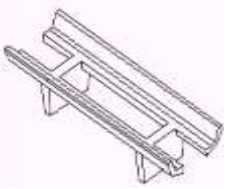

Second Application

2. Sound Walls

- reduce traffic noise
- acoustic sound barrier



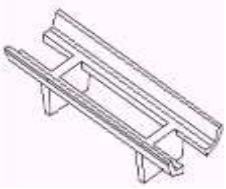

Sound Barrier Section

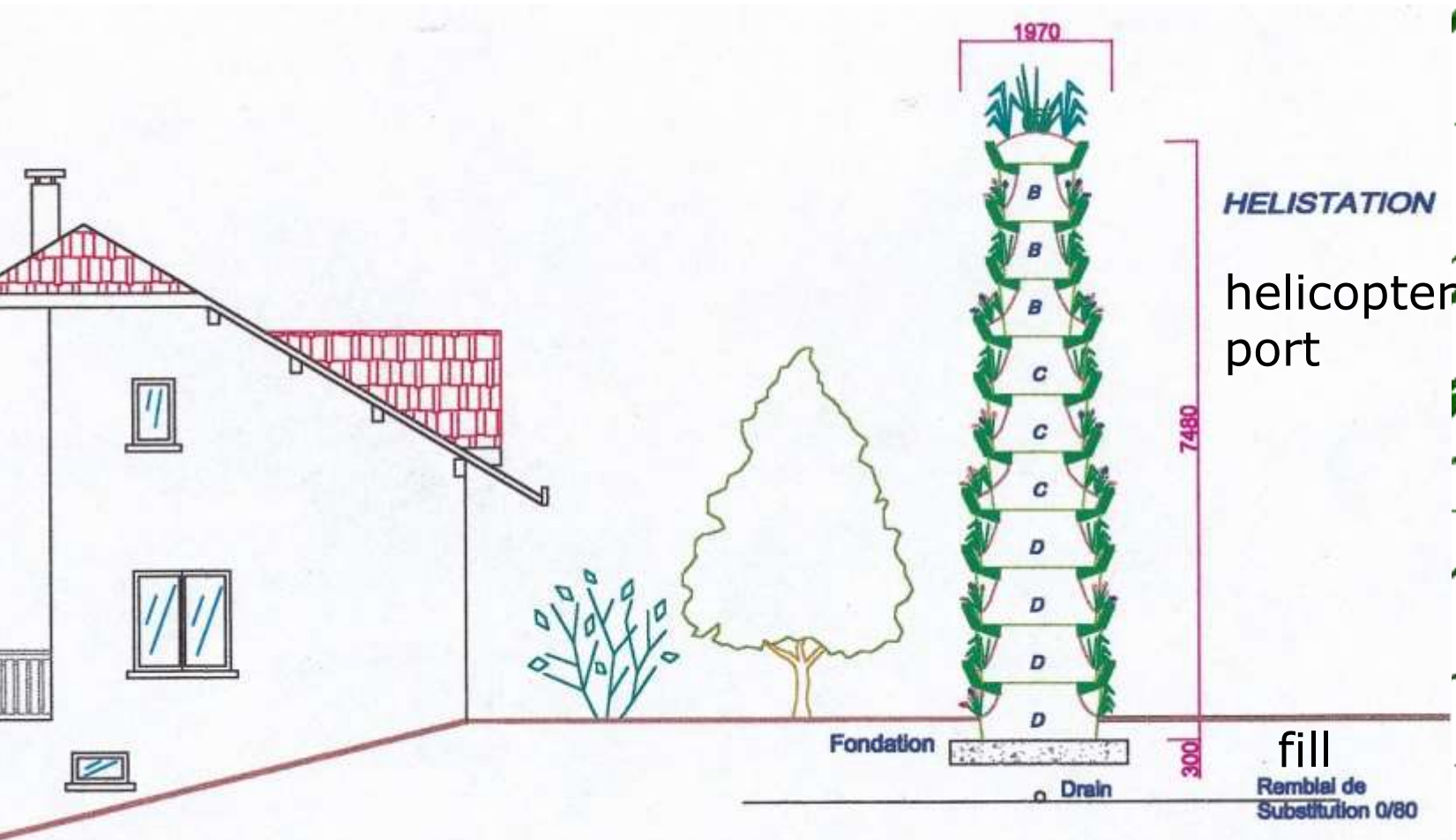

Erection of a Sound Barrier

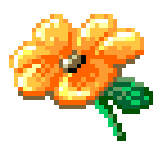
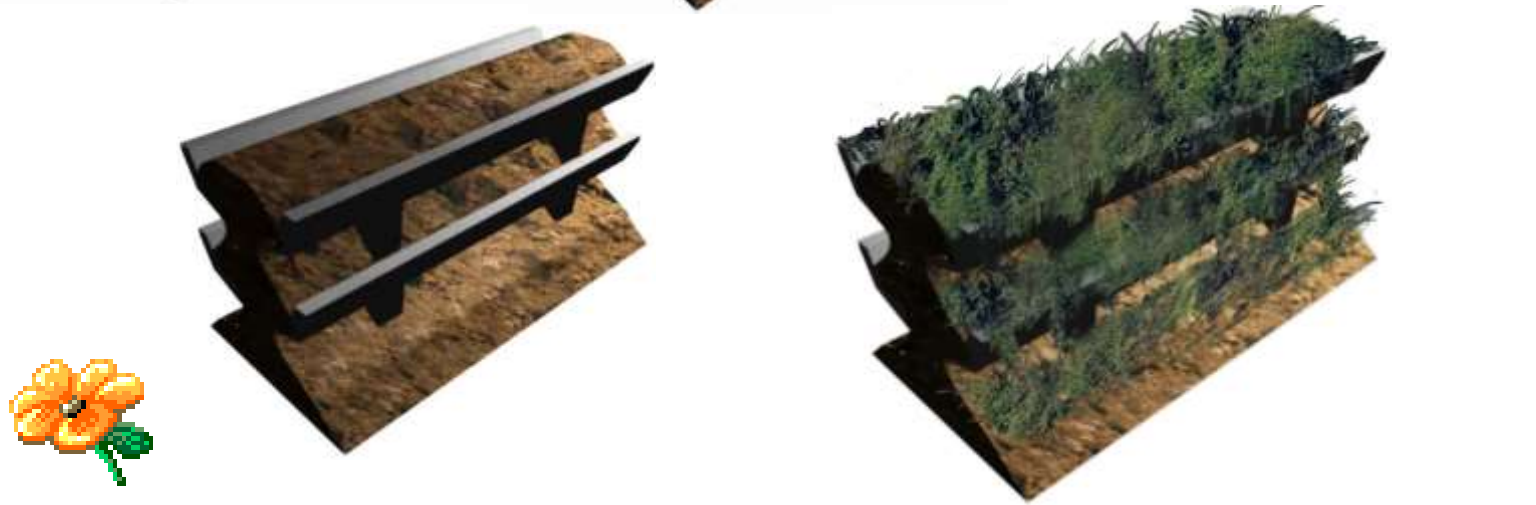
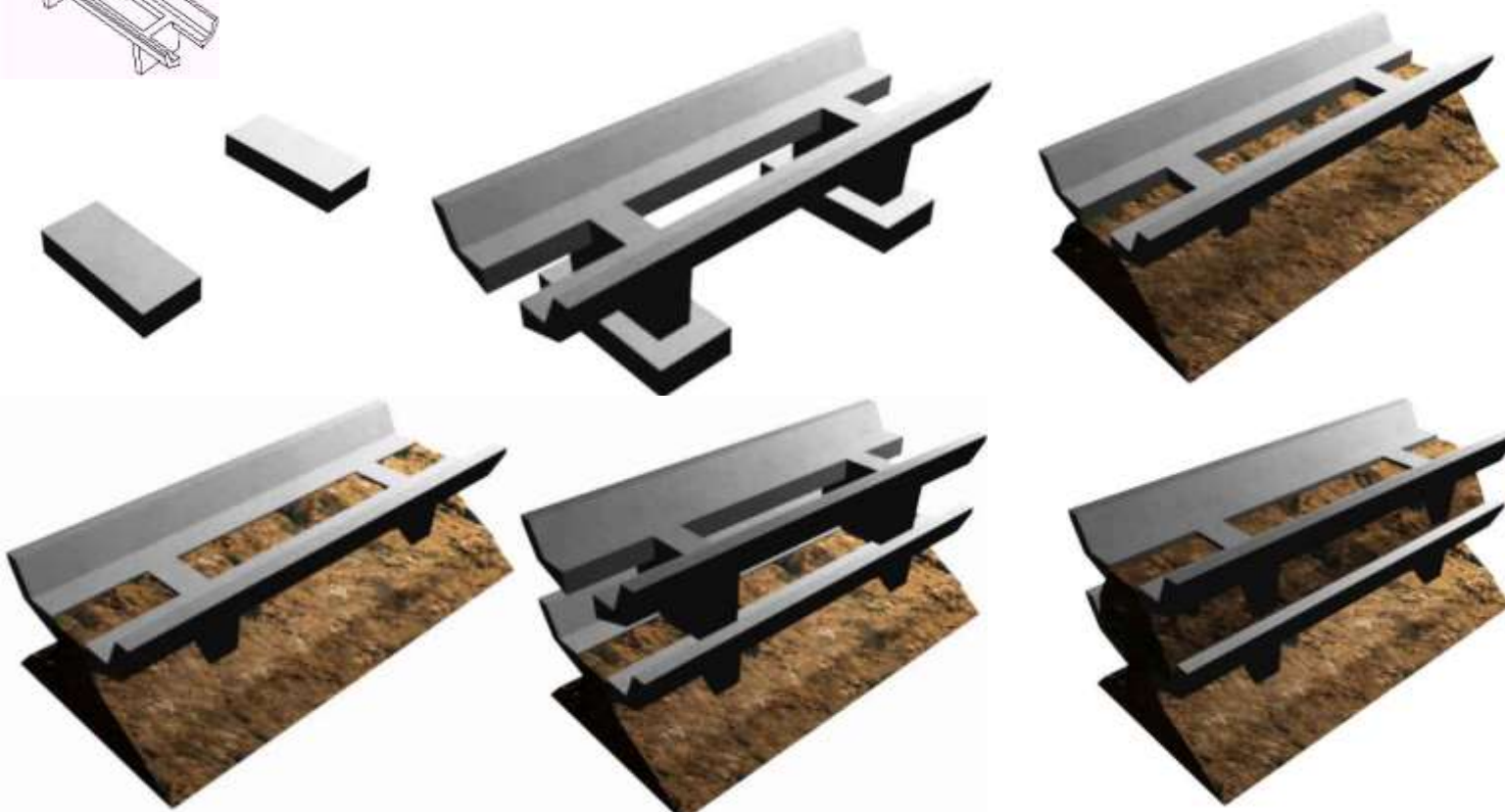
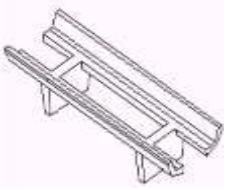

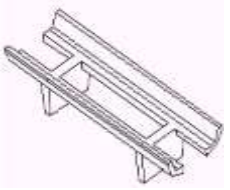

Third Application

3. Sound Walls

- Intergrate structures to the environment
- vegetated separation wall

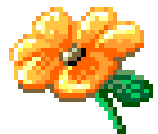

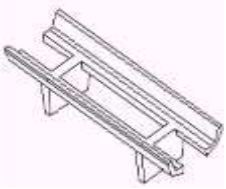

Hire a Team

- * *Profit from the competent experience.*
- * *With partners specialized in the field.*
- * *Complete and site adjusted solution.*
- * *They identify the issues*
- * *They take responsibilities.*
- * *This results good design*
- * *All construction issues covered.*

 **SYNERGY**

Ensures quality and success

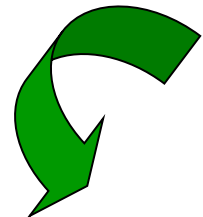
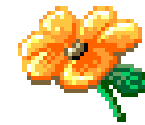

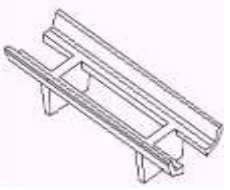

EVERGREEN

Sample Walls



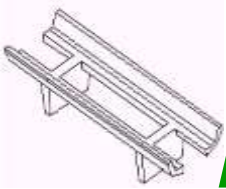

Sound Wall Against Helicopter Noise

Heliport in Chamonix, Haute-Savoie, France



Owner: Chamonix Township

Height: 7.50 m, 25 ft.

Surface: 586 m², 5600 sf

Length: 95 m, 312 ft

Erected: 1999



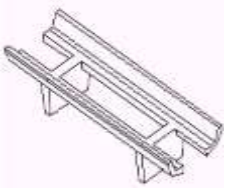

Shield Airport Noise

Brussels International Airport (Belgium)



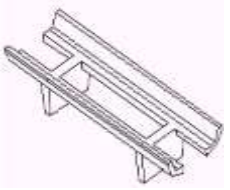

Retaining Wall for an Airport

Bilbao Airport, Spain



Owner:
Height:

Airport of Bilbao

12m, 40 ft. Length 300m, 984 ft.



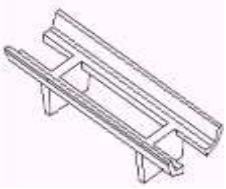

Retaining Walls For Railways

Bullet Train Station in Kassel, Germany



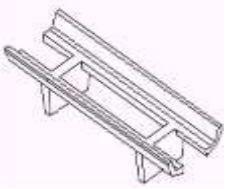

Sound Wall Along Highway

Lyon Outskirt Bron-Parilly – RN 383



Owner: DDE 69, Lyon Public Housing Authority

Height: 7m, 23 ft.

Lenght: 95ml+105ml = 200m, 660 ft.

Surface: 1070m², 11'500 sf, built in 1999



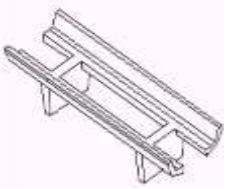

Retaining Walls on Highways

A 51 'SERF' Grenoble - Marseille



Owner: AREA, Federal Motorway Authority

Height: 17.15 m, 56 ft. **Length:** 600m, 2000 ft.



Surface: 6251m², 6728 sf built 1997/1998

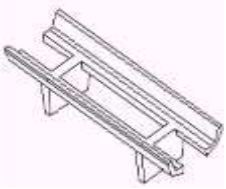

3. Rock Fall Protection Wall

A 43 - L'Escalade Cliff



Owner: SFTRF, Fréjus Highway Company

Height: 8.20m, 27 ft. **Lenght:** 270ml, 886 ft. 

Face area: 1695m², 18'245 sf **built in** 1966



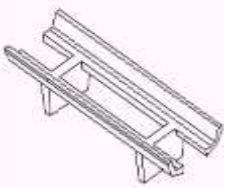

Retaining Wall

A 43 - La Chapelle –Cône du Grivolley



Owner:	SFTRF, Fréjus Highway Company		
Height:	7,55m	Lenght:	195ml
Face area:	1060m2	built in	1996



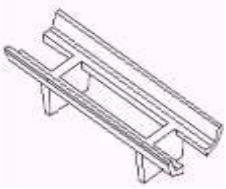

Retaining Wall

A 43 St Julien – La Gripelle Wall



Owner: SFTRF, Fréjus Highway Company

Height: 8.60 m, 28 ft.

Length: 200 m, 656 ft.

Built: 1997





➤ ***Tunnel Exit
Separation
Wall***

**Evaluate the
value of
planting**

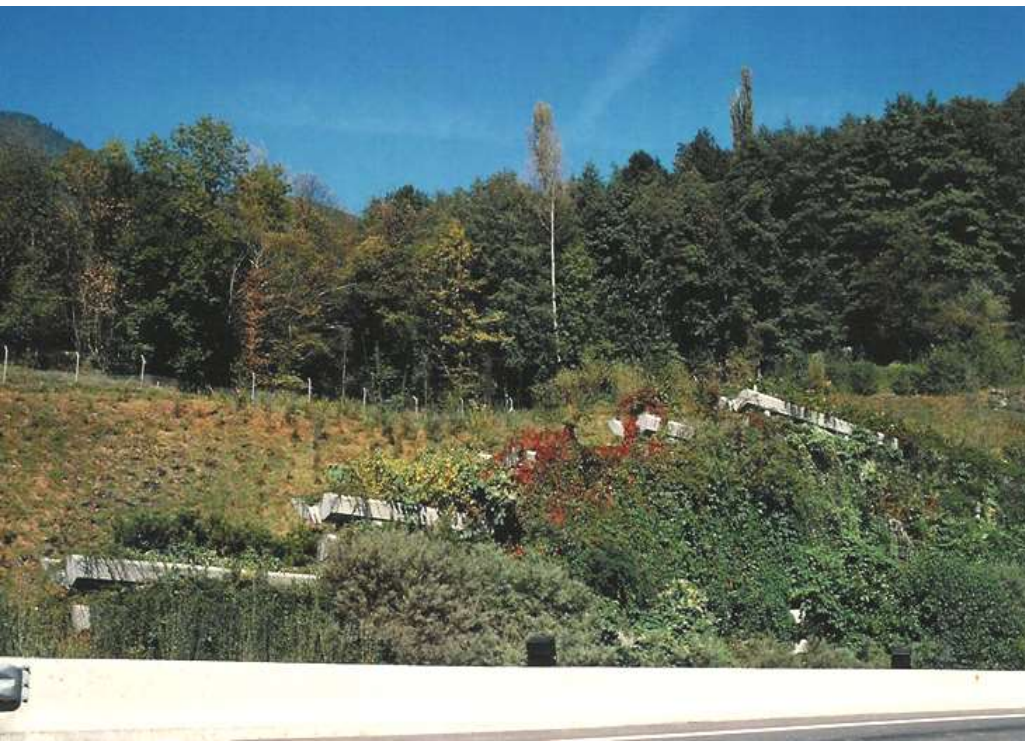

↖ after 1 year

← after 3 years



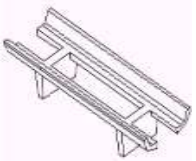

Sound and Separation Wall

A 43 - Aiguebelle - Sud, after 1 year



Owner:	SFTRF, Fréjus Highway Company		
Height:	8,75m	Length:	65ml
Facing Area:	810m²	Built:	1995



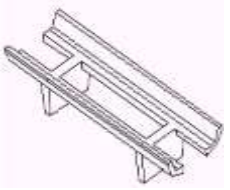

➤ ***Fire Separation Wall***

✓ Concrete Material



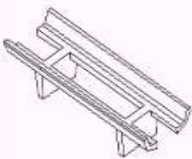

Sound and Separation Wall

A 43 - Hurtières - Sud, after 3 years



Owner: SFTRF

Height: 8,35m

Lenght: 55ml

Face Area: 650m2

Built: 1996



Separation Wall

- made of concrete units,
- covered with plants,
- illuminated for their beauty at night

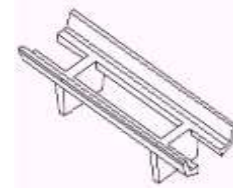

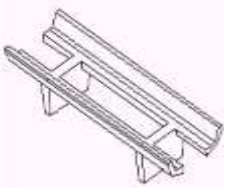

➤ *Many Options:*

simply add a sound wall on top



The units
can carry
a sound
wall on
top.



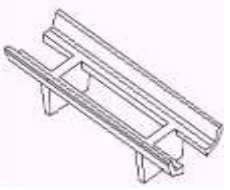

Longevity



units consist
of high
strength
factory made
quality
concrete
which last for
a long time.



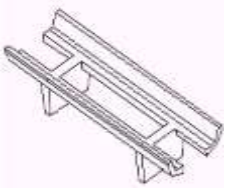

Longevity built in

- units made for longevity

High strength concrete:

- 5000 psi compressive strength
- air entrainment to resists frost cycles
- effects of deicing salts,
- biological degradation,
- ultraviolet degradation,
- road accident and impact shocks.



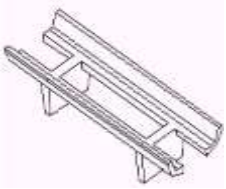

➤ ***Environmental Quality***

- ✓ **consist of concrete,**
- ✓ **filled with soil material**
- ✓ **naturally vegetated**

all natural materials



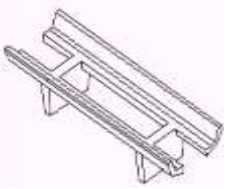

Anti-graffiti

- no paint on vegetated surfaces

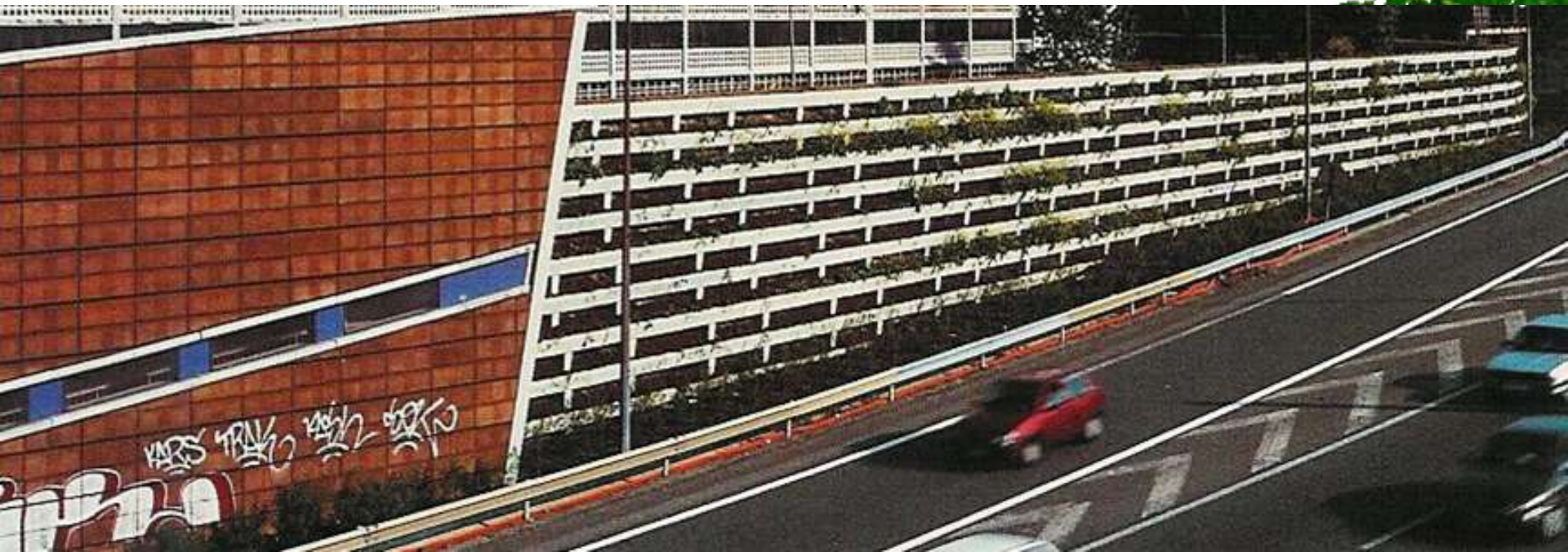

Separation Wall

- no accidental trucks on the rails.
- motorway sound remains contained.

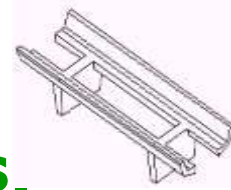



Technical Details





- **long servicelife expectancy**
- use concrete 5000 psi compressive strength

Well controlled factory production of units means high and consistent quality for long servicelife expectancy.





Reinforced Concrete Units

**Units do
not rust**



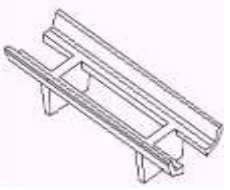

➤ *Well Founded Structure*

✓ **Concrete Foundations**

✓ **Concrete Piers**

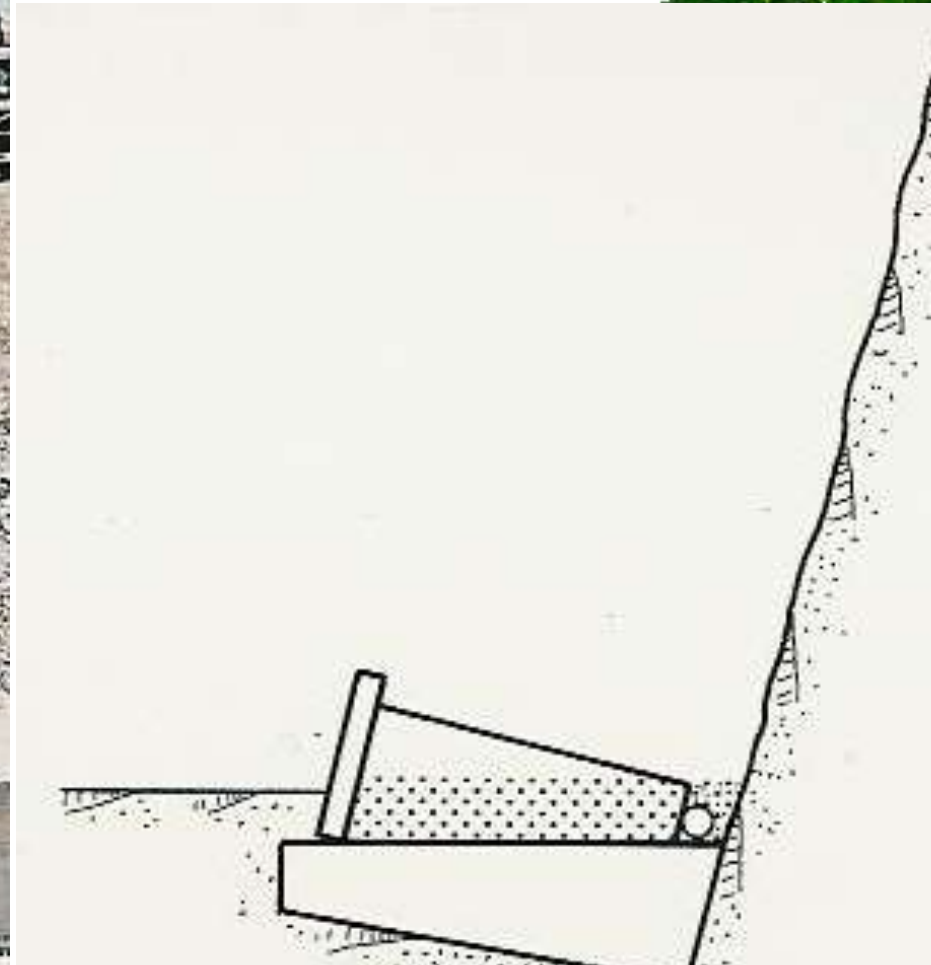



➤ ***Many Options!***

- **select units as needed for the job**

The units are piled one on top of the other.



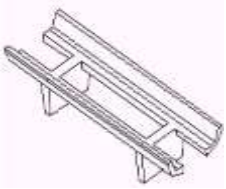

➤ *recycle units 100%*



walls can
easily be
dismanteled
and used
over again



Wall Protects Rock Nailing



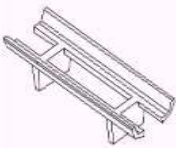

Wall Under Construction



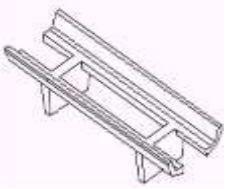

Scaffolding for Safety

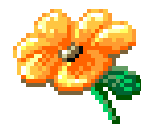

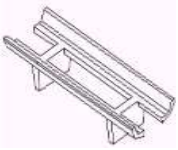

Vegetation: *before and after*



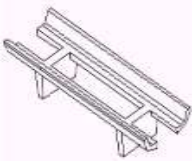

Wall Shortly After Planting



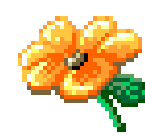
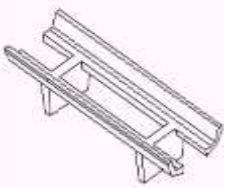

Planted Walls

environmentally favorable



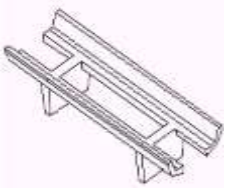

Strong Vegetation Growth:

- good resistance even in a dry year
- no effects of draught in 2003



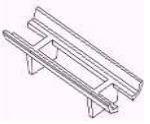

Spring Street, San Diego, USA



Retaining Wall, Long Island NY, USA



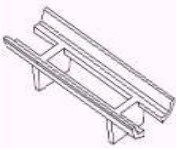

Wall at a Turn, Switzerland



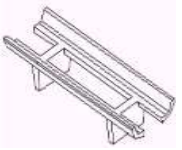

Wall in a Bend, Switzerland



Wall along tight Road Turns



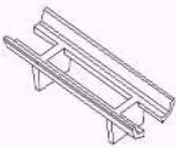

fully vegetated



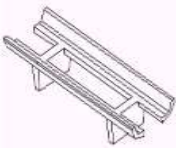

highly mixed vegetation



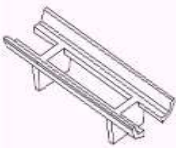

mixed vegetation



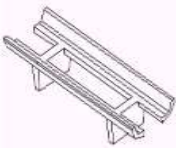

mixed vegetation



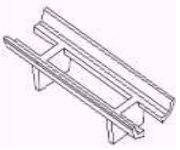

mixed vegetation



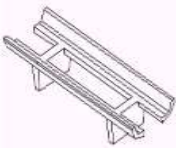

fully vegetated



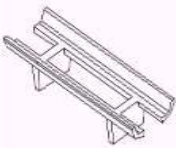

***fully vegetated,
graffity do not affect the wall***



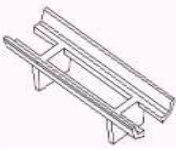

fully vegetated



parking lot behind a sound wall



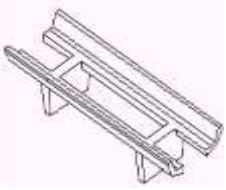

The **EVERGREEN** concept is in use around the world

✓ *Covering 12 countries on 4 continents*



**Vancouver
CANADA**



**Nihonzaka
JAPAN**

**Kassel
GERMANY**

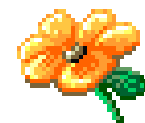

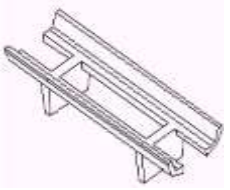

Your projet



Owner:

Height:

Face Area:

Length:

Année:



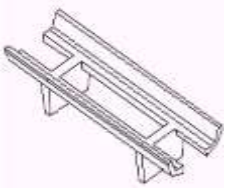

landslide stabilization

Cape Town area, South Africa



Owner: Highway Department of Cape Town Province

Height: 5.50m

Length: 250m



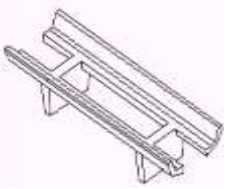

wall in desert climate



EVERGREEN®

the vegetated wall system

